



Thanks to the use of special magnet materials, this new type of circular magnets develops an extremely high holding force. Magnetising and demagnetising is achieved with a short direct current pulse. The homogeneous and precise design of the circular magnet allows hard turning and extreme material removal during turning.



DESIGN

- Uniform, strong magnetic field
- Solid pole plate
- Switch-off using demagnetising cycle
- Electro permanent magnetic system for absolute safety in case of power failure
- High accuracy thanks to pole plates bolted in a narrow grid
- Pole plate with brass, wear-protected
- Pole plate can be replaced when worn
- The radial pole positioning is particularly suitable for using pole raisers. This prerequisite is absolutely required for the runout of the tool or the grinding wheel in case of 3-sides machining. Version with T-slots (T) as per DIN 650-10^{H10} are available for this
- 8 mm wear layer on the pole plate
- Protection rating IP 65
- Available with flange on request (see SAV 248.90 to 248.94, chapter 1.2.1)

RATED HOLDING FORCE:

170 N/cm², controllable with control unit

RATED VOLTAGE, RECOMMENDED:

360 V IMP

HEAVY-DUTY POWER CONNECTOR WITH QUICK-RELEASE Optional (surcharge applies)

Easy handling of the plug-in connection

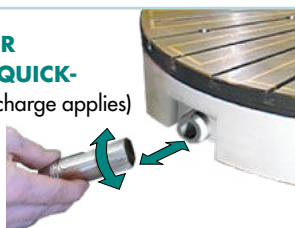

APPLICATION

Hard turning and extreme material removal for turning applications on small and large workpieces. Grinding with maximum precision.

- Same pole pitch on the circumference, therefore suitable for ring-shaped workpieces

- For workpieces up to min. width equivalent to 35 % pole pitch on the pitch circle diameter

$$P = \frac{\pi \cdot d_i + d_o}{P_p} ; B_{WKPC} > 0.35 \times P$$

- Also for thin rings

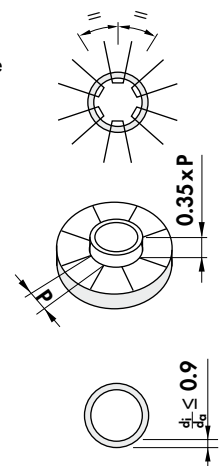

SCOPE OF DELIVERY:

- Larger circular magnets from 25 kg upwards are provided with threads for transport
- Standard version without T-slots and pole raisers
- Standard electrical connection centrally on the rear side using terminals
- Alternatively with integrated flat slip ring assembly for larger diameters from 1000 mm
- Available with water-tight heavy-duty power connector on the outer circumference on request
- Control and hand remote unit not in the scope of delivery

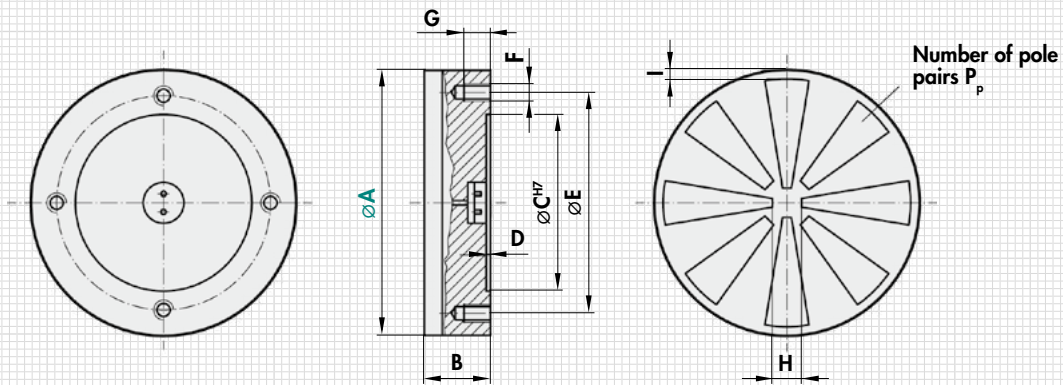

mm									Pair	kg	V	A	
A	B ₋₁ ^{0*}	C	D	E	F	G	H	I	P _p	Weight	Rated voltage	Control max. pul. Current	
200	100	110	3	140	M10 (4x)	14	45	10	4	24.0	360	30	
250	100	140	3	170	M12 (4x)	16	45	10	4	39.0	360	30	
300	100	160	3	190	M12 (4x)	16	60	10	6	54.0	360	30	
400	100	210	4	250	M12 (6x)	16	70	15	6	85.0	360	30	
500	110	280	4	320	M12 (6x)	16	100	15	8	150.0	360	30	
600	110	350	4	390	M16 (6x)	18	100	15	8	210.0	360	30	
700	110	400	4	450	M16 (6x)	18	120	15	8	280.0	360	30	
800	110	450	4	500	M16 (6x)	18	150	18	12	380.0	360	30	
1000	125	550	4	620	M16 (8x)	18	200	18	12	680.0	360	60	
1200	125	Rear side upon agreement					300	25	18	18	975.0	360	60x2
1400	135	Rear side upon agreement					300	25	18	18	1600.0	360	60x2
1500	135	Rear side upon agreement					300	25	18	18	1850.0	360	60x2
1600	135	Rear side upon agreement					300	25	18	18	2105.0	360	60x2

* On versions with T-grooves, the height increases by 10 mm.

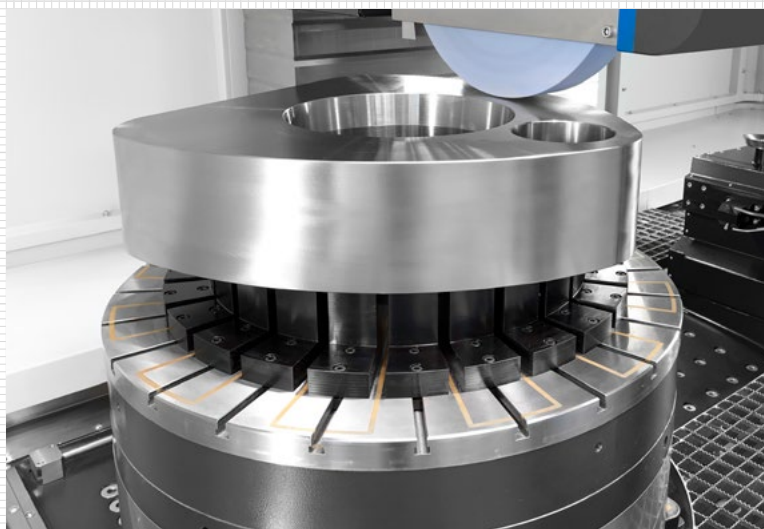

Larger diameters, e.g. 5.5 m, available on request.
Allocation to the correct control unit is based on the max. power consumption, SAV 876.17.

ORDERING EXAMPLE

Designation SAV no. - A - version - rated voltage
Electro permanent magnetic circular chuck SAV 244.71 - 1600 - T - 360 V