



Circular magnet with fine pole pitch for thin parts.
Centre also magnetically active.



DESIGN

- Pole plate with particularly narrow, continuous pole pitch, 3 mm steel and 1 mm brass
- Low height
- Pole divisions bonded and reinforced with tie rods
- High accuracy thanks to pole plates bolted in a narrow grid
- Low field height of 4 mm
- Switch-off using demagnetising cycle
- Housing annealed without stress
- Fastening hole pattern with threads at the rear or through holes upon agreement
- Electro permanent magnetic system for absolute safety in case of power failure
- 8 mm wear layer on the pole plate
- Protection rating IP 65

RATED HOLDING FORCE

- 100 N/cm², controllable with control unit using holding force coding switch

RATED VOLTAGE, RECOMMENDED

360 V IMP

APPLICATION

Grinding thin plates, wide rings with low thickness and min. widths of 40 mm.

- Suitable for placement of several small parts

- For workpieces up to:
min. thickness = 2 mm
- For flat workpieces:
Min. size = 40 x 40 mm

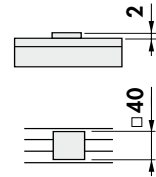

SCOPE OF DELIVERY

- Larger circular magnets are provided with threads for transport
- Standard electrical connection centrally on the rear side using terminals
- On request with water-tight heavy-duty power connector
- Control and hand remote unit not in the scope of delivery

mm								kg	A
A	B ₁ ⁰	C	D	E	F	G	H	Weight	Control max. pul. Current
300	100	160	4	190	M12 (4x)	16	213	55.0	30
400	100	210	4	250	M12 (6x)	16	301	98.0	30
500	100	280	4	320	M12 (6x)	16	401	153.0	30
600	100	350	4	390	M12 (6x)	18	481	220.0	60
700	100	400	4	450	M12 (6x)	18	581	300.0	60
800	100	450	4	500	M16 (6x)	18	681	392.0	60

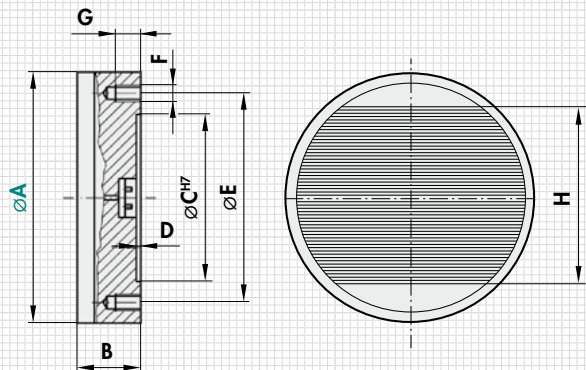

ORDERING EXAMPLE

Designation SAV no. - A - rated voltage
Electro permanent magnetic circular chuck SAV 244.73 - 300 - 360 V