

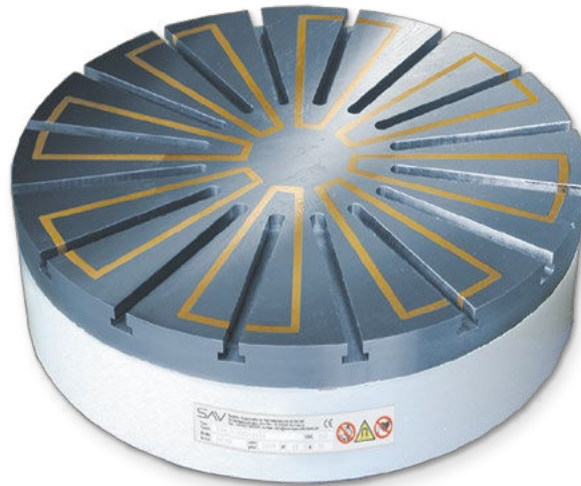

A strong magnetic field is the special feature of our circular magnets. The magnetic force is generated by the permanent magnets which are magnetised and demagnetised with short current pulses.



DESIGN

- Solid pole plate
- Switch-off using demagnetising cycle
- Electro permanent magnetic system for absolute safety in case of power failure
- High accuracy thanks to pole plates bolted in a narrow grid
- Pole plate with brass, wear-protected
- Pole plate can be replaced when worn
- The radial pole positioning is particularly suitable for using pole raisers. This prerequisite is absolutely required for the runout of the tool or the grinding wheel in case of 3-sides machining. Version with T-slots (T) as per DIN 650-10^{H10} are available for this
- 8 mm wear layer on the pole plate
- Protection rating IP 65
- Available with flange on request (see SAV 248.90 to 248.94, chapter 1.2.1)

RATED HOLDING FORCE

- 120 N/cm², controllable with control unit

RATED VOLTAGE, RECOMMENDED

210 V IMP up to size A = 400

360 V IMP above size A = 400

HEAVY-DUTY POWER CONNECTOR WITH QUICK-RELEASE Optional (surcharge applies)

Easy handling of the plug-in connection

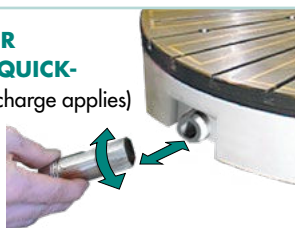

APPLICATION

Primarily for precise grinding of small to large workpieces on rotary table and cylindrical grinding machines. Also suitable for turning applications.

- Same pole pitch on the circumference, therefore suitable for ring-shaped workpieces

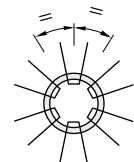

- For workpieces up to min. width equivalent to 35 % pole pitch on the pitch circle diameter

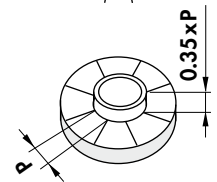

$$P = \frac{\pi}{4} \cdot \frac{d_i + d_a}{P_p} ; B_{WKP} > 0.35 \times P$$

- Also for thin rings

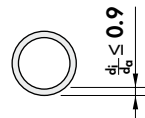

SCOPE OF DELIVERY

- Larger circular magnets are provided with threads for transport
- Standard version without T-slots and pole raisers
- Standard electrical connection centrally on the rear side using terminals
- Alternatively with integrated flat slip ring assembly for larger diameters from 1000 mm
- Available with water-tight heavy-duty power connector on the outer circumference on request
- Control and hand remote unit not in the scope of delivery

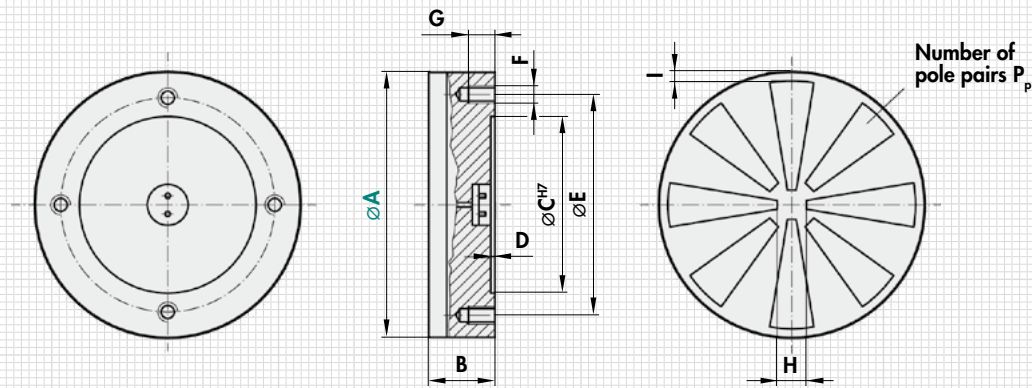

A	B _i ^{0*}	C	D	E	F	G	H	I	Pair P _p	kg	V	A
mm										Weight	Rated voltage	Control max. pul. Current
100	90	60	3	80	M8 (3x)	12	35	10	3	4.0	210	30
150	90	90	3	120	M10 (3x)	14	35	10	3	9.0	210	30
200	90	110	3	140	M10 (4x)	14	45	10	4	18.0	210	30
250	90	140	3	170	M12 (4x)	16	45	10	4	29.0	210	30
300	90	160	3	190	M12 (4x)	16	60	10	6	42.0	210/360	30
400	90	210	4	250	M12 (6x)	16	70	15	6	76.0	210/360	30
500	90	280	4	320	M12 (6x)	16	100	15	8	120.0	360	30
600	100	350	4	390	M16 (6x)	18	100	15	8	195.0	360	30
700	100	400	4	450	M16 (6x)	18	120	15	8	265.0	360	30
800	100	450	4	500	M16 (6x)	18	150	18	12	365.0	360	30
1000	100	550	4	620	M16 (8x)	18	200	18	12	550.0	360	60
1200	110		Rear side upon agreement				300	25	18	990.0	360	60x2
1400	110		Rear side upon agreement				300	25	18	1350.0	360	60x2
1500	120		Rear side upon agreement				300	25	18	1550.0	360	60x2
1600	120		Rear side upon agreement				300	25	18	1760.0	360	60x2

* On versions with T-grooves, the height increases by 10 mm.



Larger diameters, e.g. 5.5 m, available on request.

Allocation to the correct control unit is based on the max. power consumption, SAV 876.17.

ORDERING EXAMPLE

Designation SAV no. - A - version - rated voltage
 Electro permanent magnetic circular chuck SAV 244.70 - 1600 - T - 360 V